

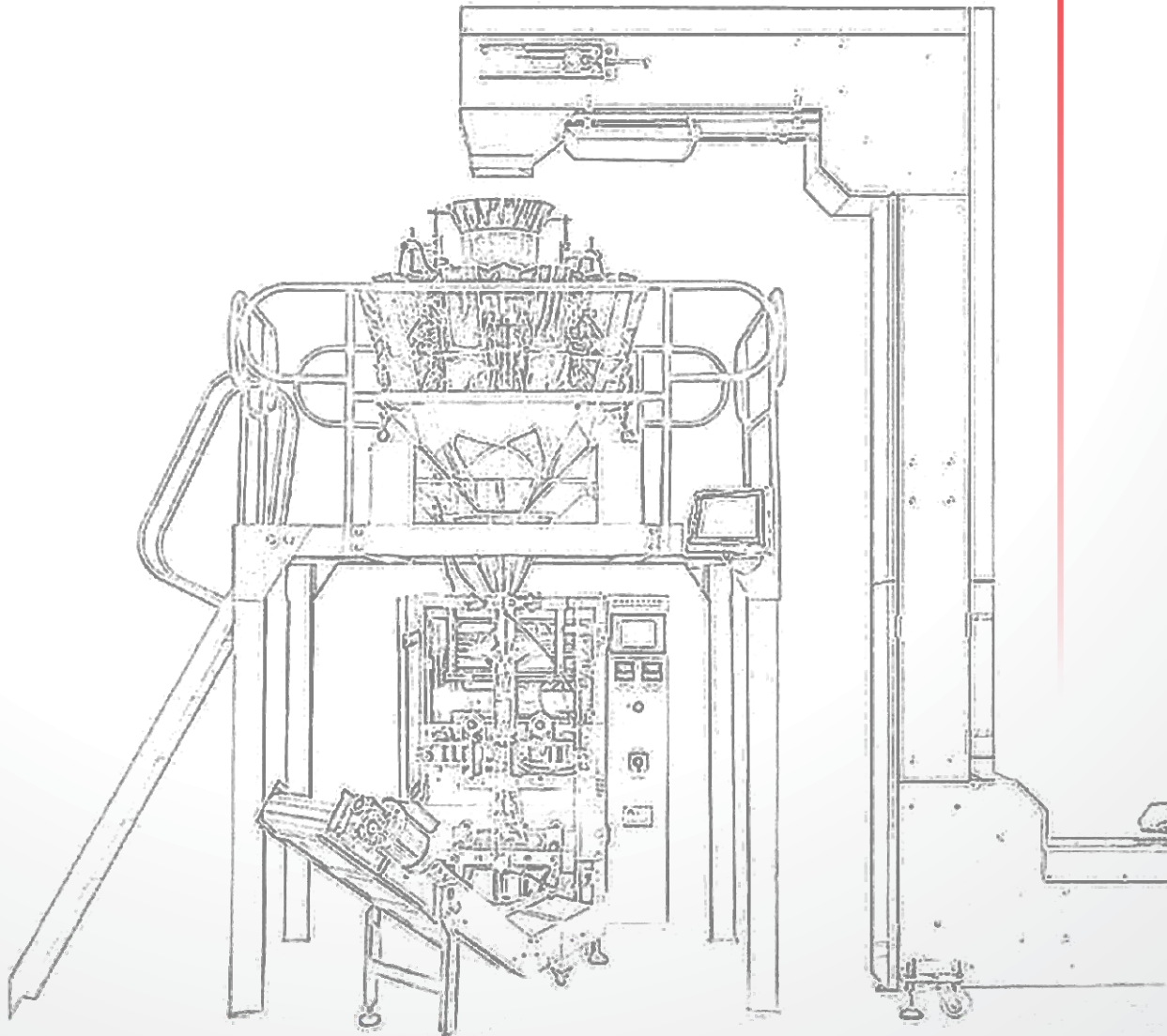

SHREE INDUSTRIES

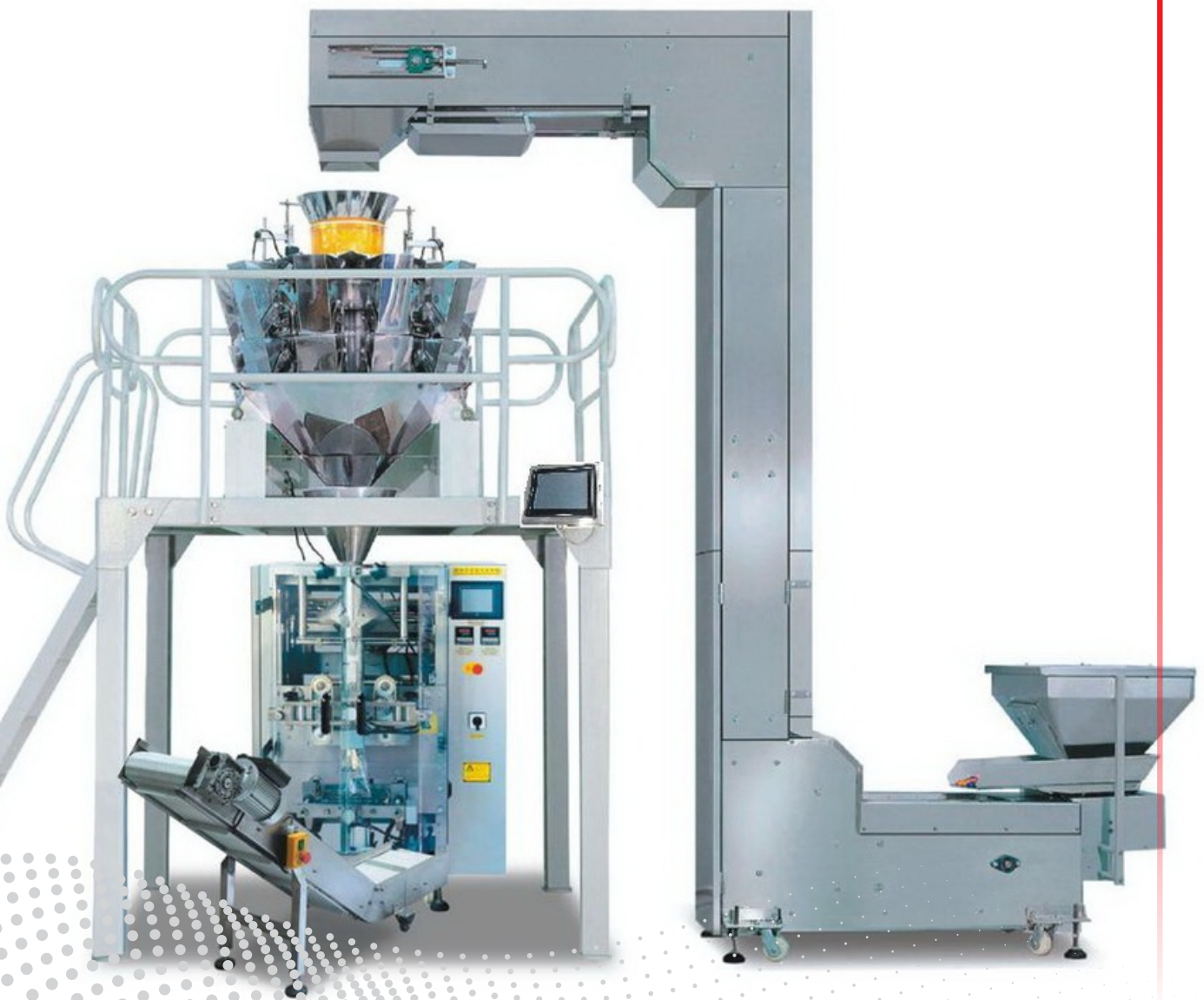

MULTI HEAD PACKING MACHINE



High speed & high precision weighing is the uniqueness of multi head weigh filler. SI Series is well known for its pouch finish & sealing intactness which prevents leakage Of inert gas from pouches & gives extended products shelf life.

APPLICATIONS

- HIGHLY SUITABLE FOR -

Kurkure and Potato Chips, Farsan, Chiwda, Namkeen, Dry - Fruits, Pulses, Grains, Tea, Sugar, Seeds, Frozen Cut Vegetable Etx.

TECHNICAL SPECIFICATION

Control	: PLC Controlled
Mode of operation	: Servo motor / Pneumatic
Filling Speed	: 1000 to 4000 pouches/hr (Depending upon the size)
Filling Capacity (Range)	: 10 g to 1 kg
Packaging Material	: Any Heat sealable Laminated Films
Power Requirements	: 420V. AC Three Phase, 50Hz
Compressed Air Req.	: 6 CFM @ 4kg/cm ²
Reel Care Diameter	: 70 mm to 76 mm Max. Weight 50 kg.
DIMENSIONS / Wt. Approx	: height - 15 ft, Length 6ft, Width 10ft 1400 kg.



SHREE
INDUSTRIES

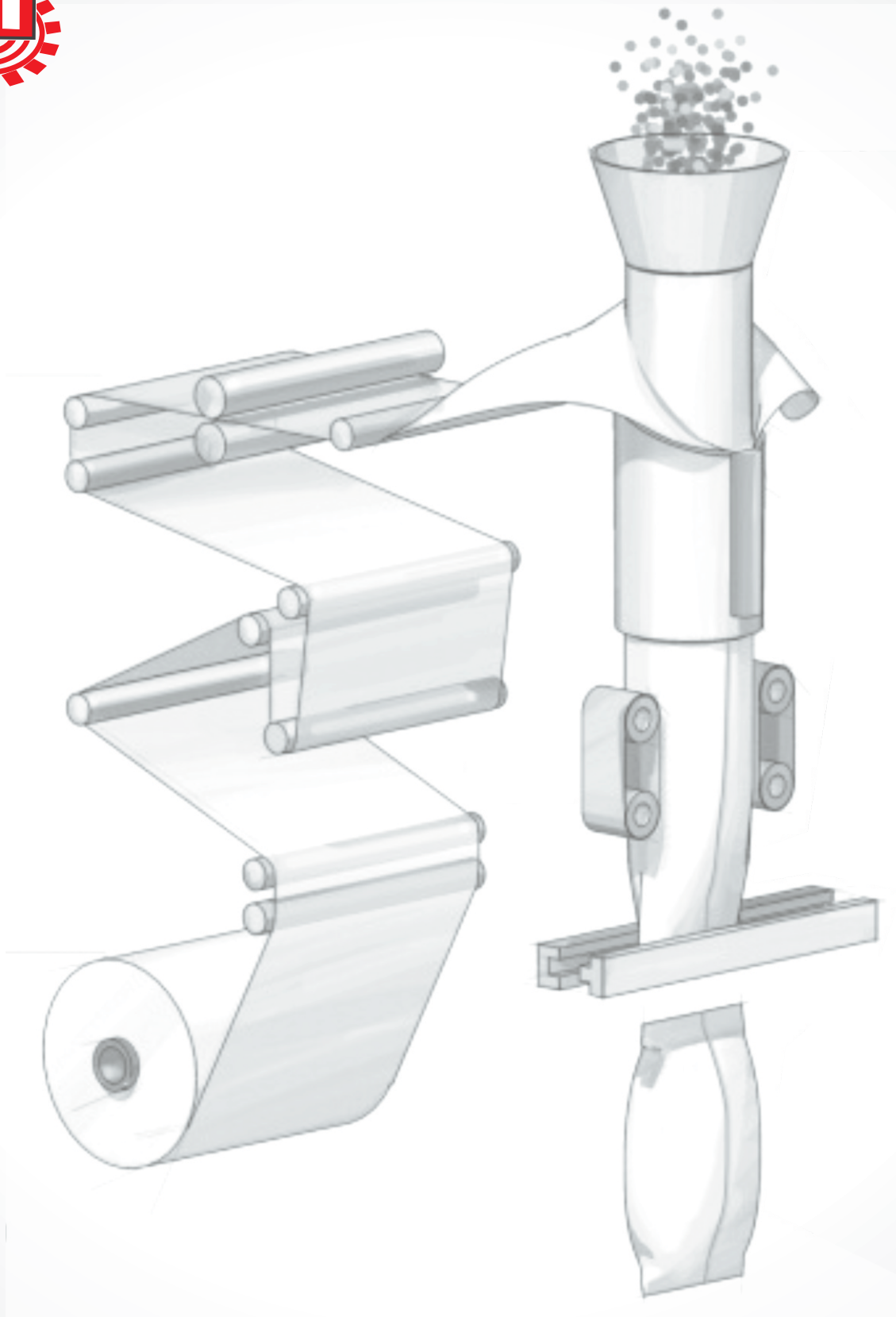

Ambica Udyognagar, Mahakali, Mandir Road, nr. AMC City Office,
Dudheswar, Shahibaug, Ahmedabad-380004, Gujarat, INDIA.

Mail : aakashpanchal311@yahoo.in / shreadind@gmail.com



Aakash Panchal : +91 99049 01711